

DESIGN SPECIALTIES

INSTALLATION INSTRUCTIONS FOR DESIGN SPECIALTIES FIREPLACE DOORS WITH SLIDE BY ROLLER SYSTEM

THESE DOORS ARE SHIPPED PARTIALLY DISASSEMBLED
THEY WERE FULLY ASSEMBLED AND ADJUSTED PRIOR TO
DISASSEMBLY FOR PACKAGING

TOOLS NEEDED:
5/16" MASONRY DRILL
FELT TIPPED MARKER
PHILLIPS SCREWDRIVER
3/8" WRENCH

5/32" ALLEN WRENCH
(FOR ADJUSTMENT)

STANDARD LEGEND SERIES HARDWARE KIT

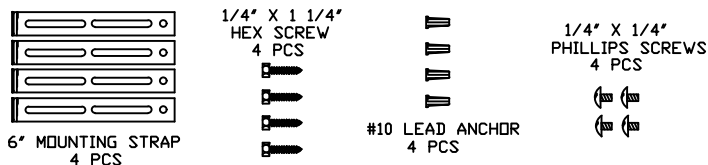

ADDITIONAL HARDWARE

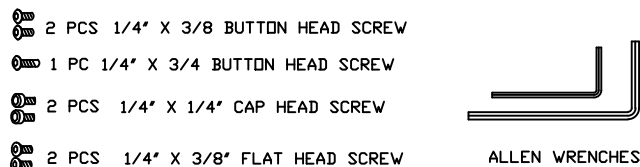

- CAREFULLY REMOVE THE FIREPLACE DOOR FROM THE PACKAGING.
YOU WILL INSTALL THE FRAME INTO THE OPENING FIRST
- LOCATE THE MOUNTING HOLES ON THE BACK FRAME.
- ATTACH THE MOUNTING STRAPS TO THE MOUNTING HOLES ON THE BACK FRAME WITH THE SCREWS PROVIDED.
- PLACE DOOR ONTO OPENING.
- BEND THE BRACKETS TO CONFORM TO THE DISTANCE FROM THE DOOR TO THE OPENING
- USE THE FELT TIPPED MARKER, MARK THE INSIDE OF THE FIREPLACE THROUGH THE SLOTS IN THE MOUNTING BRACKETS.
- REMOVE THE FIREPLACE DOOR FROM THE OPENING.
- USING THE 5/16" MASONRY DRILL , DRILL HOLES WHERE THE MARKS ARE INSIDE THE FIREPLACE 1 3/4" DEEP.
- INSERT LEAD ANCHORS INTO HOLES.
- PLACE DOOR BACK ONTO OPENING AND USING THE LAG SCREWS PROVIDED, INSERT SCREWS THROUGH BRACKETS AND INTO LEAD ANCHORS. TIGHTEN SCREWS WITH A 3/8" WRENCH.

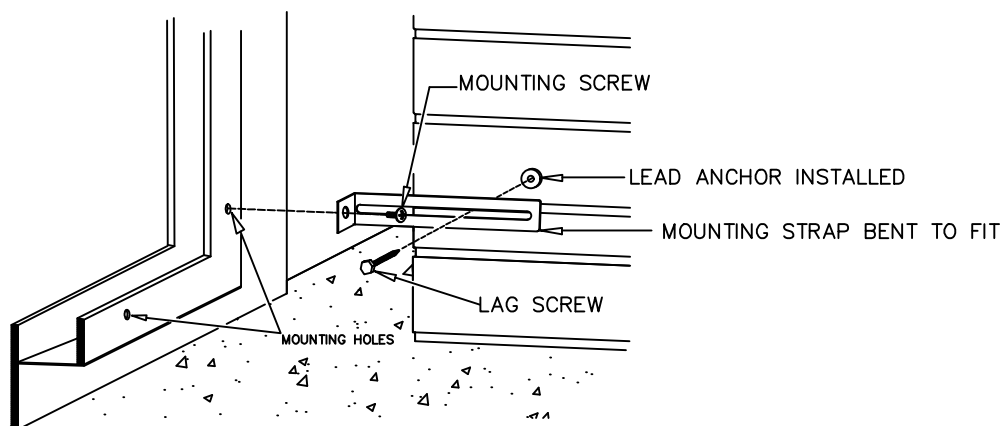

DESIGN SPECIALTIES

ONCE FRAME IS SECURED TO THE OPENING, ASSEMBLE THE ROLLER TRACK

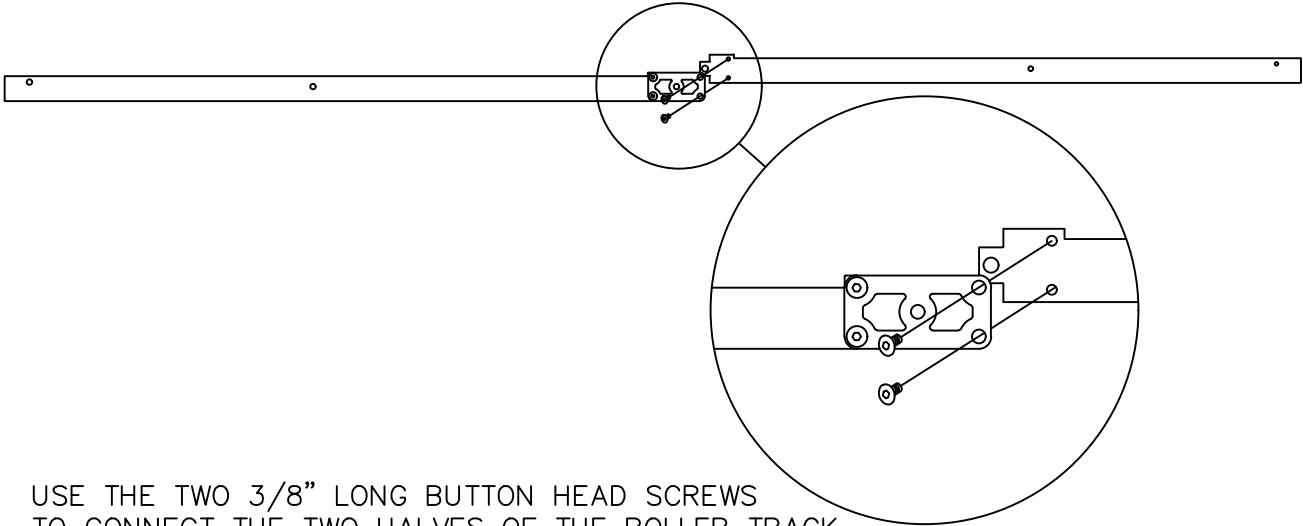

USE THE TWO 3/8" LONG BUTTON HEAD SCREWS TO CONNECT THE TWO HALVES OF THE ROLLER TRACK

INSTALL ROLLER TRACK TO FRAME. USE THE LONG (3/4") BUTTON HEAD SCREW IN THE CENTER HOLE. USE THE TWO FLAT HEAD SCREWS TO SECURE THE ENDS

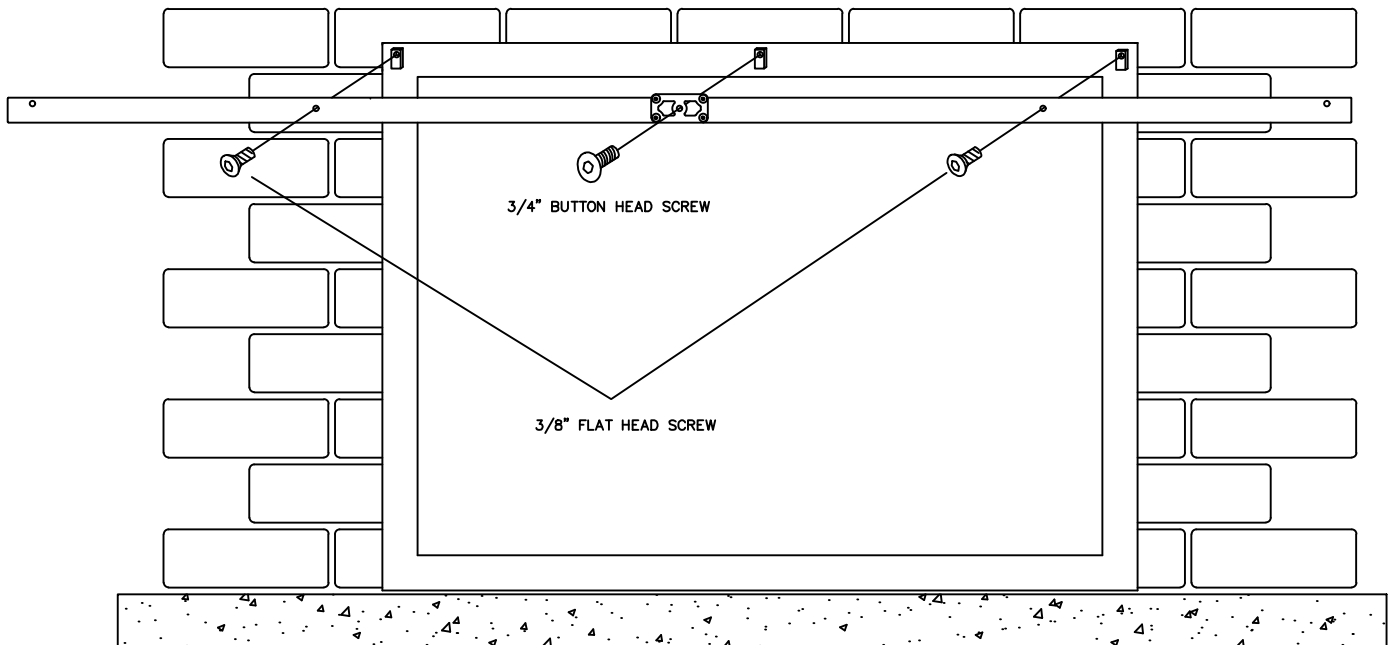

DESIGN SPECIALTIES

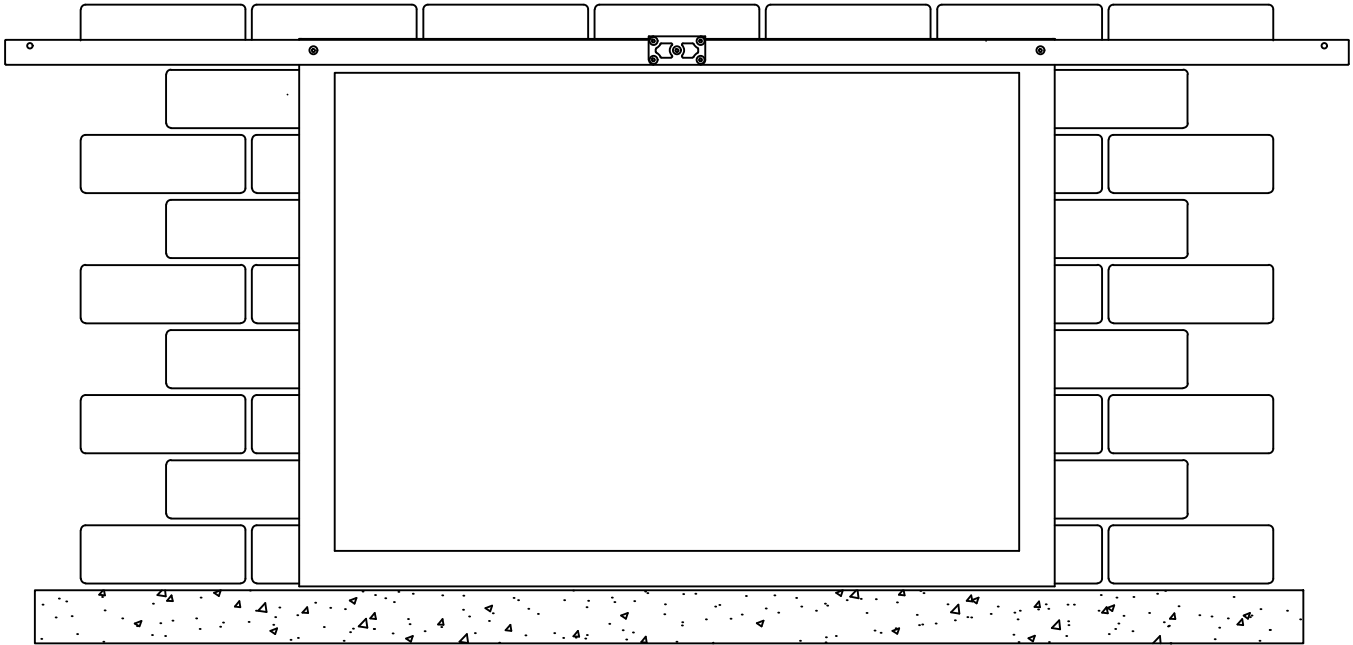

ONCE THE ROLLER TRACK IS INSTALLED, CAREFULLY SET THE DOORS IN PLACE. SET THE DOOR PANEL ONTO THE ROLLER TRACK FROM THE END. DOORS SHOULD ROLL EASILY ONTO THE TRACK. CAREFULLY ROLL TO THE CLOSED POSITION AND SCREW THE CAP SCREW INTO THE HOLE IN THE END OF THE TRACK. THIS WILL KEEP THE DOORS FROM ROLLING OFF THE TRACK

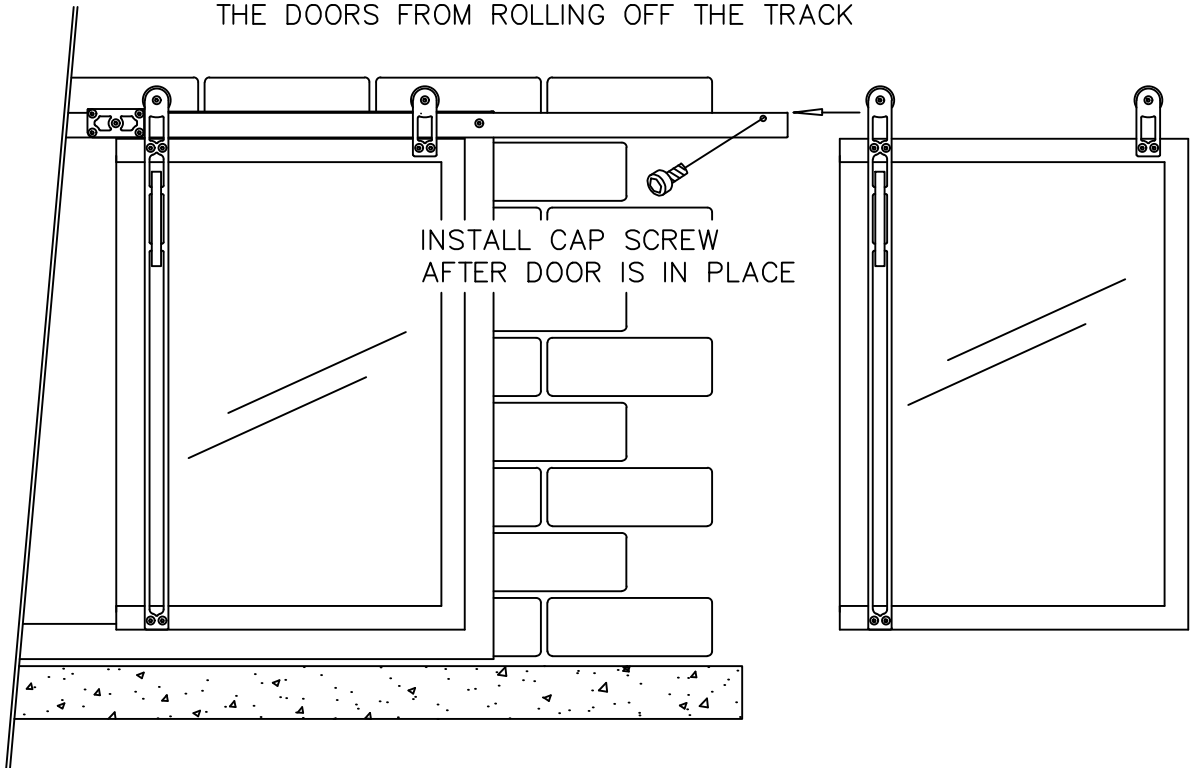

DESIGN SPECIALTIES

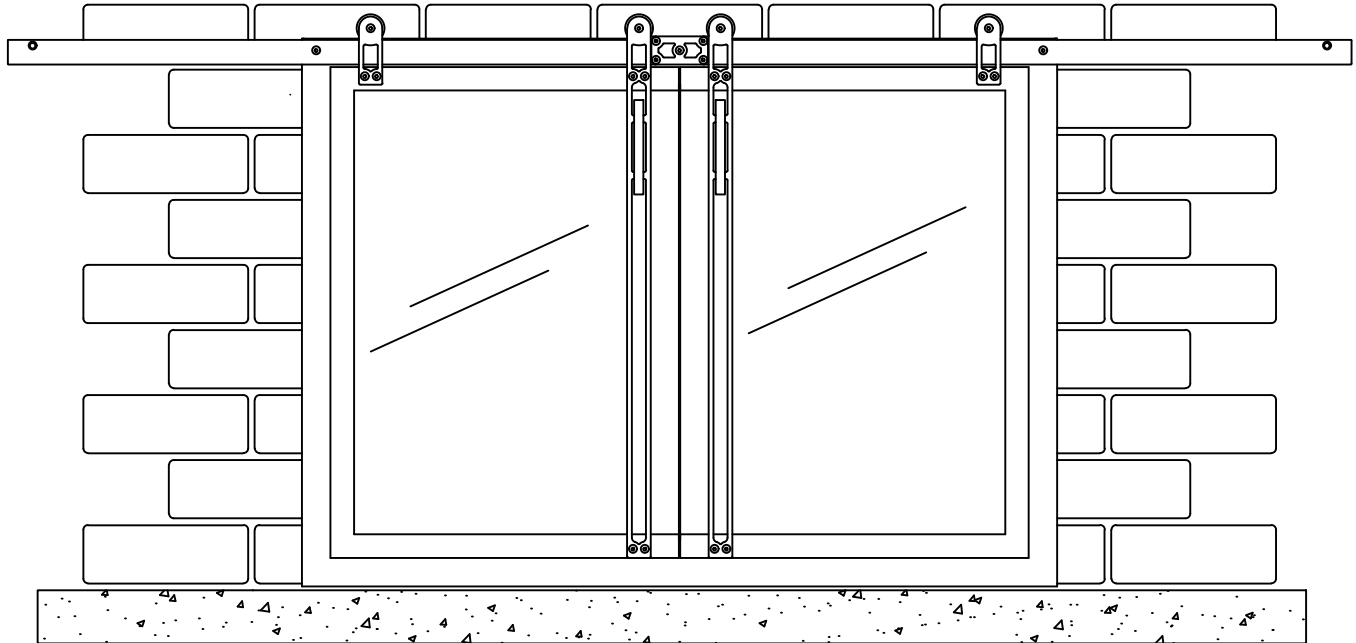

THERE IS NO ADJUSTMENT NEEDED FOR THE CENTER DOOR ALIGNMENT. IF ONE GLASS PANEL STICKS OUT FURTHER THAN THE OTHER SIDE, YOU MAY NEED TO MOVE THE BOTTOM OF THE OTHER SIDE OF THE DOOR FORWARD. LOOSEN THE MASONRY ANCHOR AND PULL THE ENTIRE DOOR FRAME FORWARD SLIGHTLY. RETIGHTEN THE ANCHOR. THIS SHOULD BRING THE DOOR BOTTOMS INTO ALIGNMENT.

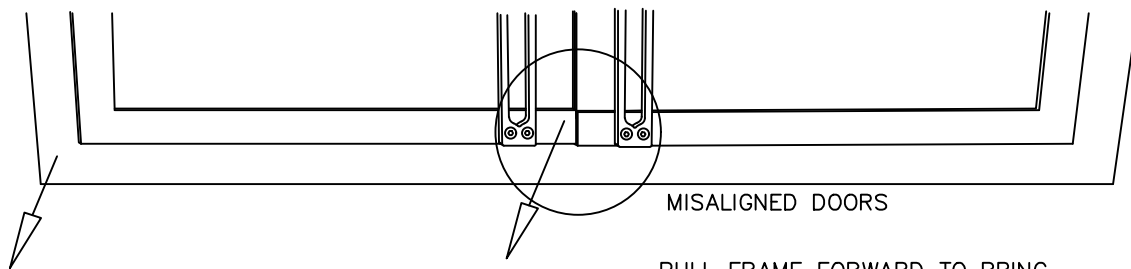

PULL FRAME FORWARD TO BRING
DOORS TO ALIGNMENT

CAUTION;

THESE DOORS ARE HEAVY AND IT IS POSSIBLE FOR THE DOORS TO COME OFF THE TRACKS. CARE SHOULD BE TAKEN TO OPEN AND CLOSE THE DOORS WITHOUT SLAMMING THEM AGAINST THE STOPS. DON'T PULL THE BOTTOM OF THE DOORS OUTWARD UNLESS TRYING TO DISENGAGE THEM FROM THE ROLLER TRACK TO CLEAN. CARE SHOULD BE TAKEN WHEN FEEDING THE FIRE TO NOT BUMP THE DOORS OFF THE TRACK.